

Constrained 3D Navigation with 2D Controllers

Andrew J. Hanson

Eric Wernert

Computer Science Department
Indiana University
Bloomington, IN 47405 USA

Abstract

Navigation through 3D spaces is required in many interactive graphics and virtual reality applications. We consider the subclass of situations in which a 2D device such as a mouse controls smooth movements among viewpoints for a “through the screen” display of a 3D world. Frequently, there is a poor match between the *goal* of such a navigation activity, the control device, and the skills of the average user. We propose a unified mathematical framework for incorporating context-dependent constraints into the generalized viewpoint generation problem. These designer-supplied constraint modes provide a middle ground between the triviality of a single camera animation path and the confusing excess freedom of common unconstrained control paradigms. We demonstrate the approach with a varied spectrum of examples including terrain models, interior architectural spaces, and complex molecules.

CR Categories: I.3.6 [Computer Graphics]: Methodology and Techniques—Interaction Techniques. I.3.7 [Computer Graphics]: Three-Dimensional Graphics and Realism. I.3.8 [Computer Graphics]: Applications.

Keywords: Navigation; Constrained Navigation; Viewing Control; Camera Control

1 Introduction

Navigation in 3D scenes, which we define as the process of selecting a continuously-changing set of viewing parameters, is a long-standing challenge for computer graphics and visualization applications. Computer animation, for example, requires the choice of a time sequence of camera models that can be considered as a one-parameter constraint; applicable techniques range from direct orientation interpolation (e.g., [19, 12]) to rule-based systems [10, 11]. The more complex task of interactive navigation has been considered in a wide variety of contexts, ranging from the viewing of simple 3D scenes on a desktop monitor to the control of fully immersive virtual reality environments. Examples of such viewing control methods run the gamut from orientation control paradigms (Brooks [4], Nielson and Olson [15], Chen et al. [5], Hanson [8], and Shoemake [21, 22]) to methods that intelligently focus on particular scene points such as Mackinlay et al. [13], constraint-based camera placement systems such as Phillips et al. [16], and general control systems such as those discussed by Ware and Osborne [27] and Drucker et al. [6]. The use of constraints in view selection specifically for virtual reality has been used, for example, by Robinett and Holloway [17] to go beyond the usual “flying” modality, and by Billingham and Savage [2] in an expert system context.

In this paper, we focus on the particular problem of using a 2 degree-of-freedom controller such as a mouse to move

effectively through a displayed 3D environment with a particular task in mind; we assume that the system designer has at least some idea of how in fact to direct a naive user’s attention to those aspects of the scene needed to meet a chosen goal. We then present some very specific families of techniques that may be used by the designer to constrain the user’s motion in ways that avoid the “lost-in-space” pitfalls of most airplane-style or helicopter-style controls with up to 6 (or more) degrees of freedom. Our fundamental notion is that, rather than controlling an unconstrained vehicle in 3D space, the 2D control device is actually moving the user on a constrained subspace, the “guide manifold,” a kind of virtual 2D sidewalk. At every sample point of this virtual sidewalk, we may specify a “guide field” containing all the information the designer wishes to supply to a customizable algorithm computing the viewing parameters for the user. Typically, both the guide manifold and the guide fields are specified only at sample points, and interpolation methods are used to determine intermediate values. The manifold itself may be continuous, may consist of disjoint pieces, or may even cross over itself to give it “Riemann-manifold” properties that let the traveler traverse a circuit over and over to the same spot, and each time be presented with a new set of guide parameters. The parameters of the guide field may supply arbitrarily complex information to the designer’s algorithm; we illustrate the power of the idea using applications to terrain navigation, architectural structures, and complex molecules. An evaluation of several basic features of the paradigm is currently in progress.

Combining Displacement Constraints and Viewing Constraints. There are several effective ways to construct a framework for constraint-based navigation in 3D viewing situations. In the simplest version, we just extend the one-parameter camera path of a traditional animation to a two-parameter surface in 3D space navigated by mouse strokes; each point of the surface incorporates a fixed camera-model field. In many cases, the data themselves provide a context of interest, and can thus be used to modulate a fixed viewing-parameter field relative to the source of interest.

The field variables may be fixed *a priori* at key vertices using designer-specified camera models (orientation plus focal length) and interpolated among key vertices; or the field variables may be computed from procedures combining fixed fields, dynamic or static scene data, and current viewer position and state (e.g., velocity). It then becomes the designer’s problem, not the viewer’s, to minimize the “lost in space” effect, and thus to optimize the viewer’s ability to focus on the task that is the goal of the navigation.

A related example of such a system was introduced for the exploration of complex mathematical manifolds in Hanson and Ma [9]. The key constraint in this original concept was the idea that every direction on a 2D manifold implies a geodesic path determined by the intrinsic geome-

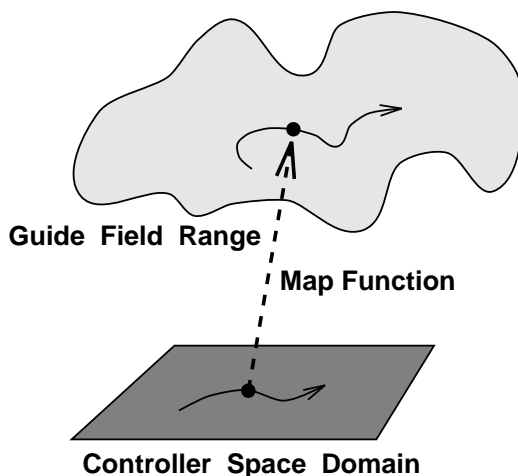

Figure 1: Diagram of the general mathematical concept of a guide field and its ramifications.

try; the manifold itself provides a constraint on the navigation by providing a “platform” on which the user walks and which continually rolls up to meet the viewer’s feet, keeping a constant relative orientation between the viewer’s vertical and the surface normal. This path automatically determines an orientation in response to directional changes of the 2D mouse control. The more general concepts proposed in the current paper follow from the realization that the manifold on which the viewer is “walking” could in fact be an *invisible sidewalk* created for the purpose of seeing *other* things in the surrounding world, and that the geodesic-constrained orientations can easily be replaced by a completely arbitrary field of quaternion orientations combined with a tandem field of focal lengths and additional viewing and control parameters if appropriate.

Below, we propose several additional families of dynamic procedures for determining the current camera parameters in addition to fixed key vertex values and the geodesic interpolation methods of Hanson and Ma [9]; these range from methods based on metric relations between the navigation surface and the nearby scene or terrain, to methods that could be based on arbitrary rules in the manner of Karp and Feiner, or Billingham and Savage [10, 11, 2]. While we focus here on 2D mouse-based interfaces, the framework clearly extends to immersive virtual reality environments, where the virtual space of the control device can select points and orientations in a 3D volume, instead of simple 2D mouse coordinates. We defer exploration of such issues for the time being in order to focus here on fundamental concepts of direct application to the most common visualization systems.

2 Fundamental Methods.

The basic idea behind our approach is the concept of a mapping a controller domain into a guide field range consisting of the parameters needed to modify the construction of the scene image and possibly also parameters modifying the influence of the controller. This is represented schematically in Figure 1. We begin with a bare controller position (u, v) , assuming the implicit availability of heading and velocity information (\dot{u}, \dot{v}) , and define a map $\mathbf{G}(u, v)$ from the domain of the control device to the full space Φ of parameters. In principle the range of the parameter space can include

anything, even computed quantities. Thus we write

$$\mathbf{G} : (u, v) \mapsto \Phi, \quad (1)$$

where objects in the range Φ include such things as

1. Camera position on guide manifold; the point in the universe where the virtual owner of the device appears to be standing.
2. Camera Orientation; where the virtual user is looking.
3. Focal Length. Wide angle, telephoto lens, depth of field, and binocular convergence are all basic effects that can be called up on demand.
4. Viewing Range (for fog, etc.)
5. Control modifiers; (mouse response, etc.)

By retaining successive values of these fields in the control program, the designer can also create rate-of-change-dependent responses.

For most practical purposes, the controller domain corresponds locally to a path in the guide manifold that is equivalent to a surface in the 3D world. However, one can imagine applications in which more general mappings might be useful. For example, one might instead use the mouse position to vary a two-parameter camera orientation (θ, ϕ) , treat this orientation as the independent variable of the guide manifold, and treat spatial position as a dependent guide field variable attached to each point of (θ, ϕ) in the guide manifold. Therefore, we retain all the scene-viewing parameters in a single data structure, and treat its space as a type of *fiber bundle* (see [7, 23]) for which we choose a projection and a section. All that means for us is that, whichever guide field variables we choose to map the controller to, we need a consistent *projection operator* to make that the “base space” in the sense of fiber bundle theory. The remainder of the space contains the dependent variables, and a choice of section amounts to the selection of particular set of parameters (e.g., one camera orientation out of the space of possible viewing angles at that point in the base space, etc.). The dependent variables are typically determined by selecting samples on a lattice, and thus we must smoothly interpolate all these variables in tandem with a smooth interpolation of the base space coordinates.

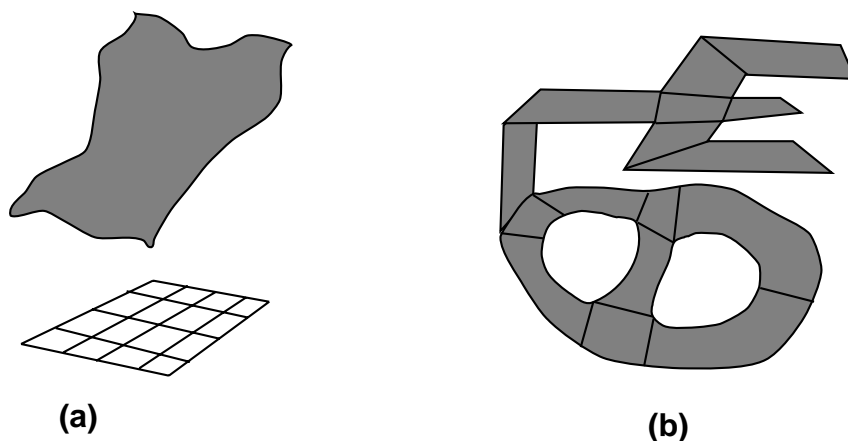

Figure 2: (a) A rectangular patch in mouse space (below), lifted to a guide surface in 3D (above). (b) A network of rectangular guide patches pieced together into a generalized guide surface using winged edges to relate one patch to another.

Winged Patches. The simplest relation from the controller space to the scene viewing parameters is generated by a single rectangular patch corresponding one-to-one with the 2D mouse position, as done in Figure 2a. To create navigable manifolds over more complex situations, we must sew together many of these fundamental pieces to form an *atlas*. An example of kinds of navigable manifolds that result from merging many simple patches is provided in Figure 2b.

Modulation by Data. We can immediately go beyond the already useful idea of having predetermined camera parameters at each point of the navigable space by defining *modifiers* of the default parameters. In Figure 7, we show the result of using the gradient $\nabla\phi$ of the terrain elevation model as a cue: starting with a constant “up” direction, we rotate the camera by a weighted amount to face a bit towards the gradient into the valley.

An explicit example is the following: at each point of the coordinate-space guide manifold, determine the “heads up” direction of the camera frame $\hat{\mathbf{u}}$, the “look at” direction of the camera frame $\hat{\mathbf{k}}$, and projection $\hat{\mathbf{p}}$ of the terrain gradient onto the plane perpendicular to $\hat{\mathbf{u}}$; then, if $\cos\phi = \hat{\mathbf{p}} \cdot \hat{\mathbf{k}}$ describes the angle between the projected terrain gradient and the camera gaze direction, one rotates the camera about the $\hat{\mathbf{u}}$ vector by $c\phi$, where $c = \|\hat{\mathbf{p}}\|/\|\hat{\mathbf{p}}_{\max}\|$ is the relative magnitude of the projected gradient strength.

Interest Vectors. Interest vectors are a generalization of the data modulation method of the previous paragraph. When the viewer is positioned at any point in a particular scene, the designer may record both viewer information, such as gaze direction \mathbf{g} , and a direction of interest \mathbf{d} in the scene appropriate to the current viewer state. These typically provide sufficient information to specify a context-based, weightable state change for the camera model. A typical example would compute the plane containing \mathbf{g} and \mathbf{d} and rotate about the direction normal to that plane, $\mathbf{g} \times \mathbf{d}$, by an angle that is either small, for passing interest, or sufficient to place \mathbf{g} exactly in line with \mathbf{d} , for very high interest. In other cases, the “up” direction of the camera frame may be fixed or constrained, making a rotation about the $\mathbf{g} \times \mathbf{d}$ forbidden; in such circumstances, we project \mathbf{d} onto the plane perpendicular to the “up” direction and use the

projected vector as the interest direction instead, as in the data modulation example.

Fog, Spotlights, etc. The actual scene appearance can equally well be modulated to suit the designer’s needs. We suggest the following methods: (1) Fog. As one passes through a scene, one can limit the visibility to a handful of key regions by obscuring the most distant objects. Other application-dependent depth cues can be used if appropriate. (2) Spotlights. Whether or not the camera model allows you to change its gaze, you can shine a spotlight on any desired sector to emphasize it. This is very easy in OpenGL, requiring only the definition of a few key-frame values of a direction. The spotlight need not be large, nor coincide with the gaze or motion directions. See Figure 8 for an example.

Vista Points. A fundamental context-defining technique available in such a navigation system is the “scenic overlook.” This is very much like an overlook on a vacation highway, except that the signposts and annotated vista points can be placed anywhere in 3D space continuously connected to the sidewalk. As the viewer approaches the critical vista point itself, changes in the focal length, camera orientation, and control response can be imposed by the designer to exactly emulate features such as Mackinlay et al.’s [13] controlled approach, or even “dynamic field glasses” that focus in on distant scene features as though one had donned zoomable binoculars to pan across the scene of interest, similar to one scenario of Robinett and Holloway [17]. An example is given in Figure 9.

Multiple Coverings. Another fundamental technique is the “multiple covering” navigation surface. (People with mathematical backgrounds will recognize this as a relative of Riemann surfaces in complex variable theory.) Here, one creates a surface that may come back to the same point by many different routes; a simple example is a double circle, as shown in Figure 3, which allows the camera to point in one direction the first time around the loop, in another direction the second time, and return to the original state the third time around. An explicit application is depicted in Figure 11. The reader can imagine arbitrarily complex variants, including instantaneous state transitions between entirely different guide fields.

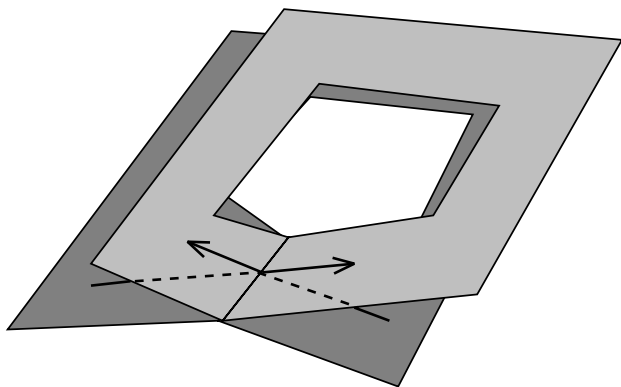

Figure 3: An example of a navigation manifold that contains more than one possible layer, hence more than one possible camera model, depending on one's route to the scene (two inequivalent states are illustrated by the arrows).

Variable Sensitivity Fields. A number of applications have identifiable areas where one wants to have very fine control, and others where one wants coarse control for quickly traversing large, uninteresting areas. We note two examples that fit cleanly into our framework: (1) Velocity-based displacement. Several common commercial mouse interfaces already support this feature: the velocity of the mouse is measured, and as the speed increases, the overall displacement is amplified accordingly, allowing quick navigation to all corners of the screen. (2) Response field. Here, we just define a scalar field over the guide manifold and use it to magnify or reduce the bare controller displacement at each local point. Effects such as those to those of Mackinlay [13], could be achieved without the use of scale factors simply by refining the mesh near the critical points of the guide manifold. However, it is quite tricky to make the changes occur smoothly in such a mesh, and the continuous scale change field overcomes this. Figure 4 illustrates a field that causes very small responses in the foreground depression where the scale is 0.1, and very large responses at the background peak, where the scale approaches 3.

3 Designing Constrained Navigation Applications

3.1 Basic Components

Our constrained navigation paradigm in its basic form requires an interactively renderable 3D scene plus the following:

- **Constraint Surface.** A surface data structure every point of which can be reached in a predictable manner by incremental motions of a 2D mouse. In practice, one would therefore almost always use as building blocks rectangular arrays of 3D points corresponding to projecting onto the 2D rectangular mouse coordinates. These can be joined as in Figure 2b to form a patchwork of polygons that can be navigated in the manner of Hanson and Ma [9]. More complex surfaces (e.g. multiple coverings, multi-branched soap-bubbles) may be used in a similar fashion for particular applications. The most intuitive constraint surface is a sidewalk-like

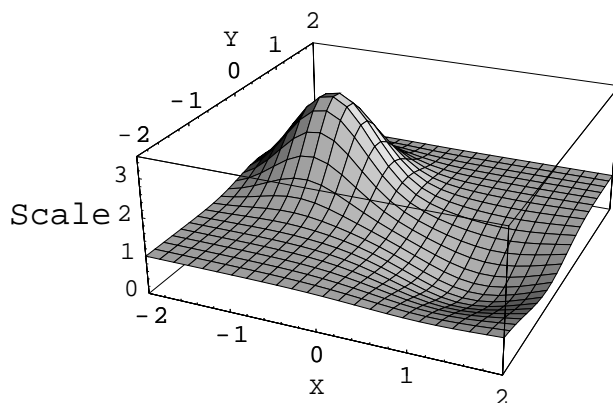

Figure 4: A scaling field that could be used, in regions of value greater than unity, to magnify the screen distance traversed by a unit mouse motion; similarly, in regions of value less than unit, this field would slow the mouse response to provide extremely fine-grained control in those limited areas where it is required.

mesh of 3D points, but nothing prevents us from choosing, e.g., latitude and longitude of camera orientation.

- **Camera Model Field.** At each point of the constraint surface, the designer must attach those values of the camera model field complementary to the constraint surface (orientation if the constraint surface is spatial, position if the constraint surface is orientation, etc.). Thus at each point of the constraint surface array we typically construct a data structure consisting of the variables $\mathbf{G}(u, v) = (x, y, z, q_0, q_1, q_2, q_3, f)$, which describe the 3D position, the orientation in terms of a quaternion frame, and the focal length (or perhaps the camera frustum). In practice, these fields would normally be specified at key vertices and interpolated to the intermediate points of the constraint surface.

3.2 Interpolation

Given the normal situation where only a finite number of sample points appear in the array of camera model fields, we require $\mathbf{G}(u, v)$ to be interpolated at intermediate points. This is typically accomplished for rectangular sample spaces by taking the sixteen enclosing grid values forming a local 3×3 square of nine grid squares and performing a bicubic Catmull-Rom spline interpolation, thus ensuring that all grid field values are actually on the interpolated surface. Quaternions must be used to achieve smooth orientation interpolations as noted by Shoemake [19, 20], and refined in subsequent work such as that of Schlag [18], Nielson [14], and Kim, et al. [12]; 2D rectangular extensions of these methods are straightforward. (*Note:* One might use more complex interpolation methods such as a 2D minimal-surface version of the quaternion minimal path solutions of Barr, et al. [1], but these would likely be too time consuming for most real-time applications.) Other variables such as the focal length and controller response field can be interpolated similarly in tandem.

3.3 Methods for Determining the Camera Model Field

We next present a selection of approaches that can be used to determine the camera model structure at any particular point of a navigation path.

Constant key vertices. The simplest configuration utilizes a designer-supplied grid of constant camera parameters, along with a procedure for interpolation among the grid points. The predefined key vertex method is well-adapted to many classic applications, and can easily be understood (and even defined) as a family of deformations of a single fixed camera-animation path.

Constant key vertices modified by terrain. “Fly-through” or terrain-traversal applications are a special and ubiquitous scene class that can take particular advantage of constrained navigation to curb the tendency to wander aimlessly in free flight. If we assume a computable direct mapping between a point in the (u, v) constraint parameter space and a point on the terrain, we can detect and compute terrain features as a function of (u, v) . These can in turn be used in many ways to modulate the user’s attention. See section 2 for a detailed example.

Modifications based on designer-supplied interest field. Another flexible method is related to the level-set method for implicit surfaces (see, e.g., Blinn [3]). By defining a 3D scalar function that is large near a selected family of scene points, the designer can specify an “interest field” to show where the user’s attention should be directed whenever the user draws near; the corresponding implicit surfaces define manifolds of equal “attention importance” in the navigation space, and could be displayed optionally as navigation cues. If $f(\mathbf{x})$ is the function so defined, the camera model can be made to turn its attention from the current gaze direction towards the nearest interest point by choosing the interest vector discussed above as the gradient ∇f of the interest field. A variety of other strategies would clearly work to store this same type of information; we like the 3D scalar field approach because highly complex information can be simply specified and edited by the designer. Note that a separate interest field can in principle be supplied for each parameter, allowing, e.g., the camera focal length, to be varied independently in complex ways throughout the navigation.

Space-walk frames and constrained “up” fields. The basic manifold traversal method of Hanson and Ma [9] can be used with 2D constraint manifolds of arbitrary complexity, and is extensible to 3D as well. Effective use of the method requires data stored in a winged-edge format rather than the simpler 2D parametric rectangular grid format that we have implicitly assumed for most of the discussion. The intrinsically defined transitions from polygon to polygon allow one to navigate a complex surface keeping the world “up” direction aligned with the surface normal throughout the transversal. While it is natural to have the gaze direction pointed in the direction of motion, this is not required; fixed camera parameters can be prestored at each vertex and modulated either by scene features or the default space-walk camera frame.

Another interesting variant is to specify only the “up” direction of the camera frame at each point (manually or from the normal to the constraint manifold); then the camera has a single rotational degree of freedom at each point that

can be determined from the context, e.g., viewer velocity, or other data.

3.4 Dynamic Mapping Techniques

Several prospects for more complex control strategies appear promising for future work.

Lead time. Sometimes we want to have the system react to where we *will* be, not where we are. This leads one to define systems that have symbolic “guide dogs” trotting in front, and requires some predictive computation. Once the hypothesized guide position is determined by the designer’s algorithm, the rest of the procedure would be standard.

Viewer state procedures and rules. The user state in a navigation problem contains a number of variables that can be tracked and computed, particularly those involving velocity and heading history (see, e.g., some of the techniques reviewed in Chen et al. [5]). Arcade games often exploit such information, particularly to add challenge to a control strategy by preventing direct manipulation of the object to be controlled. In physical simulations, momentum, friction, and air resistance play a crucial role in making driving and flight simulators realistic. Such factors can be incorporated into the procedures or rules determining the evolution of the camera field on the constraint surface to accomplish a number of intuitive physical effects.

Context-based rules. A variety of approaches have been proposed in the literature to use context-based knowledge, expert system domain rules, and artificial intelligence planning methods to determine transitions among camera positions in animation or even complete animation paths (see, e.g., [10, 11, 2]). It is clearly appropriate to apply such techniques to the more general philosophy of constrained navigation proposed here; this is a fertile area for future research.

4 Examples

In this section, we present a series of examples realized by implementations using the Open Inventor class libraries in the SGI Explorer and Open Inventor environments; we note in particular that many of the needed quaternion-based classes and methods are already supplied. We implemented our own Catmull-Rom interpolator based on the Schlag algorithm [18].

Wandering Camera Path with Wandering View. In a traditional computer animation, the camera itself may follow many different constraints such as looking at a single point on the ground throughout the motion, tracking a moving object in the scene, or staring in a fixed direction. Figure 5(a,b) shows a generalization of the latter with the viewer’s trajectory confined to a plane. In Figure 6a, the path is still constrained to the plane, but designer-placed camera orientations are used as key vertices for a quaternion spline interpolation; Figure 6b shows the scene viewed from the same point as Figure 5b, but with the modified camera field.

Terrain Navigation: Conservative Flight Path. In Figure 7, we show a more realistic guide manifold for navigating a terrain model; we employ a contoured 3D constraint surface and constrain the camera “up” vector to be the surface

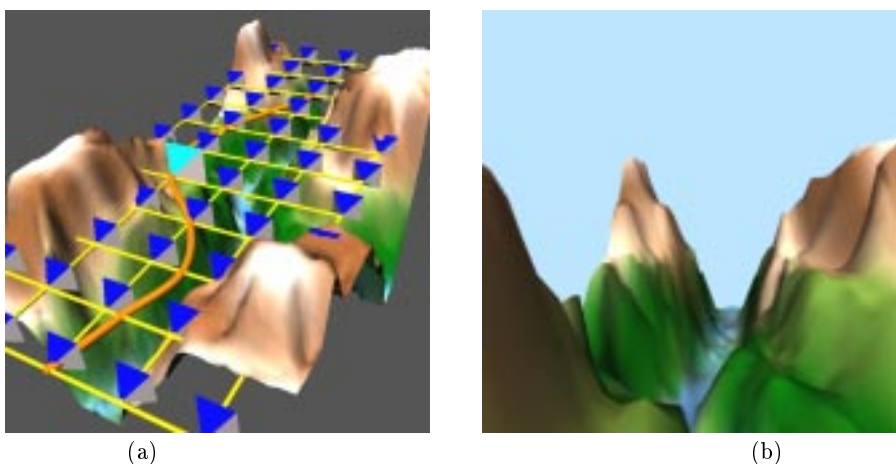

Figure 5: Camera path constrained to plane with fixed camera orientation. (a) View of path and camera model control points on constraint surface. (b) View using camera model field at selected point.

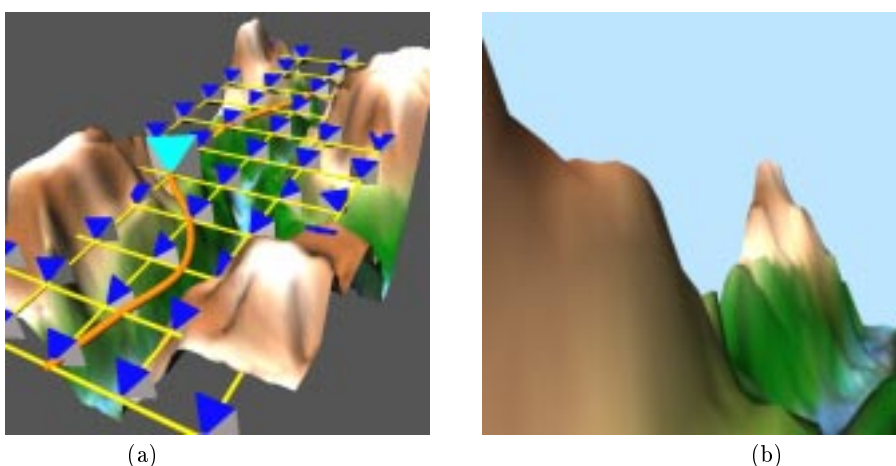

Figure 6: Camera path constrained to plane with camera orientation modulated by terrain gradient. (a) View of path and camera model control points on constraint surface. (b) View using camera model field at selected point.

normal. The camera orientation at each point is determined by rotating relative to the constant gaze direction to look slightly in the direction of the terrain gradient below. We note that we need not require a global “up” direction; if desired, we can transition smoothly from “right-side-up” in the world to “upside-down” (see below).

Spotlight Attention Focus. An example of the spotlight technique, which can be used to focus the user’s attention on a point that is not necessarily aligned with the direction of the camera gaze or the direction of motion, is shown in Figure 8

Terrain Navigation: Vista Point Ahead! A tour designer in the paradigm presented here has not only the ability to keep wandering users in a limited set of viewpoints and to keep their attention focused only on what they are supposed to see, but also to prepare special treats. In particular, the constraint surface itself may vary dramatically, and the focal length can be controlled and interpolated throughout the grid just like the other variables. In the scenario presented in Figure 9, the designer has placed two “vista points” in

the scene which the user may approach at will while roaming the constraint space. Figure 9a focuses on one particular point that causes the user to rise rapidly above the world to a very high vantage point, while the camera is forced to look down below at the retreating scene data, creating the view of Figure 9b. Figure 9c is rather like a highway rest stop, where approaching a particular point on the constraint surface swings your gaze direction around, points at a landmark you might never have noticed otherwise, and puts a “telephoto lens” on the camera so that the viewer automatically zooms in on the point in question.

Molecule Navigation. The most challenging applications for constrained navigation involve the perusal of objects with no natural orientation. Here we have both the advantage of being permitted great flexibility, and the drawback of having to decide on a particular guiding strategy. Figure 10a shows how we have chosen a toroidal navigation manifold that entirely envelops a helical molecule. This constraint surface allows us to move quickly to every conceivable viewpoint on the molecule with a series of very simple mouse strokes. To keep the user in context, we make the “up” direction inside the molecule the same direction as outside,

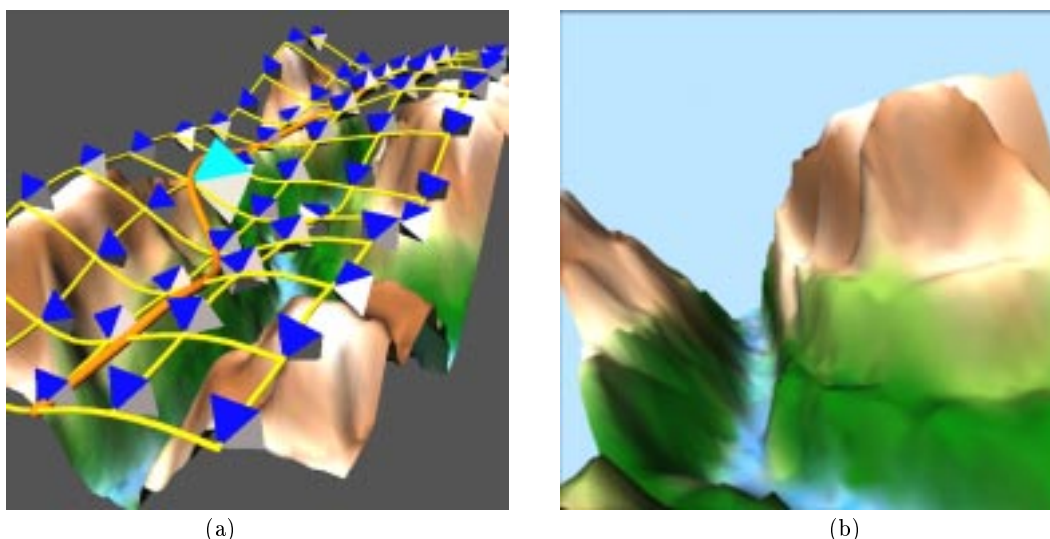

Figure 7: Camera path constrained to complex surface with camera orientation keyed to constraint surface normal and modulated by terrain gradient. (a) View of path and camera model control points on constraint surface. (b) View using camera model field at selected point.



Figure 8: Spotlight focused on an area of interest that is slightly displaced from camera gaze and motion directions. This allows greater flexibility in keeping the context while redirecting attention.

while tilting a bit at the top and the bottom to keep focused on the structure and give a clear end-on view, as shown in Figure 10c. Here the goal of the navigation was to give the viewer a fluid way to see every conceivable surface, inside and outside, of the virtual cylinder around which the helical molecule is wrapped.

Building Navigation. More complex topologies arise naturally when we examine complex 3D structures such as buildings and room interiors. Here it is natural to include new levels of constraints and choices. In the example of Figure 11, we restrict user motion in a single room to encircle an object of interest, which happens to be a model of a virtual reality environment. This simple example of a multiple-patch data structure is used to define a double circuit of “carpeting” around the object of interest like that noted also in Figure

3; this guide manifold serves both to prohibit areas with physical obstructions, and to permit different things to be emphasized on even and odd tours around the room. Thus, the goal of the first circuit of the walkway is to focus on the display screens, while the second time around we use an effective interest field to focus instead on the placement of the projectors.

5 Conclusion

In this paper, we have introduced an extension of the one-parameter camera path of a traditional animation to a multiparameter space appropriate for constrained navigation in both 3D desktop and immersive virtual reality environments. Detailed examples have been worked out and presented for the particular case of a 3D through-the-screen display controlled by a 2D mouse. The basic procedure is to supply a sampled set of view-determining data at each point of a “virtual sidewalk.”

Substantive human factors studies of the comparative effectiveness of particular scenarios are beyond the intended scope of this paper; nevertheless, an evaluation of alternative constrained exploration modes is currently being pursued for room-like worlds, using criteria inspired by those of Thorndyke et al. [26, 25, 24]. Other future plans include the development of context-dependent, state-dependent, history-sensitive expert systems to recompute the camera model at each step the viewer takes on the journey. But whatever the embellishments, in the end it is up to the designer to limit the viewer’s freedom of navigation just enough to prevent loss of context, but not so much as to disturb the feeling of exploration and discovery appropriate to the viewer’s task.

Acknowledgments

AJH gratefully acknowledges the cordial hospitality of Claude Puech and the members of the iMAGIS laboratory, a joint project of CNRS, INRIA, Institut National Polytech-

nique de Grenoble, and Université Joseph Fourier, where this research was initiated. Thanks are also due to the staff of CICA, the Indiana University Center for Innovative Computer Applications, for their support. This research was made possible in part by NSF infrastructure grant CDA 93-03189.

References

- [1] A. Barr, B. Currin, S. Gabriel, and J. Hughes. Smooth interpolation of orientations with angular velocity constraints using quaternions. In *Computer Graphics Proceedings, Annual Conference Series*, pages 313–320, 1992. Proceedings of SIGGRAPH '92.
- [2] M. Billinghurst and J. Savage. Adding intelligence to the interface. In *Proceedings of VRAIS '96*, pages 168–175, 1996.
- [3] James F. Blinn. A generalization of algebraic surfaces. *ACM Trans. on Graphics*, 1:235–256, 1982.
- [4] F.P. Brooks. Walkthrough — a dynamic graphics system for simulating virtual buildings. In *Computer Graphics*, pages 9–21, 1987. Proceedings of 1986 Workshop on Interactive 3D Graphics.
- [5] Michael Chen, S. Joy Mountford, and Abigail Sellen. A study in interactive 3-d rotation using 2-d control devices. In *Computer Graphics*, volume 22, pages 121–130, 1988. Proceedings of SIGGRAPH 1988.
- [6] Steven M. Drucker, Tinsley A. Galyean, and David Zeltzer. Cinema: A system for procedural camera movements. In *Computer Graphics*, pages 67–70, 1992. Proceedings of 1992 Symposium on Interactive 3D Graphics.
- [7] T. Eguchi, P.B. Gilkey, and A.J. Hanson. Gravitation, gauge theories and differential geometry. *Physics Reports*, 66(6):213–393, December 1980.
- [8] A. J. Hanson. The rolling ball. In David Kirk, editor, *Graphics Gems III*, pages 51–60. Academic Press, Cambridge, MA, 1992.
- [9] A. J. Hanson and H. Ma. Space walking. In *Proceedings of Visualization '95*, pages 126–133. IEEE Computer Society Press, 1995.
- [10] P. Karp and S. Feiner. Issues in the automated generation of animated presentations. In *Graphics Interface 1990*, pages 39–48, 1990.
- [11] P. Karp and S. Feiner. Automated presentation planning of animation using task decomposition with heuristic reasoning. In *Graphics Interface 1993*, pages 118–127, 1993.
- [12] Myoung-Jun Kim, Myung-Soo Kim, and Sung Yong Shin. A general construction scheme for unit quaternion curves with simple high order derivatives. In *Computer Graphics Proceedings, Annual Conference Series*, pages 369–376, 1995. Proceedings of SIGGRAPH '95.
- [13] J.D. Mackinlay, S. Card, and G. Robertson. Rapid controlled movement through a virtual 3d workspace. In *Computer Graphics*, volume 24, pages 171–176, 1990. Proceedings of SIGGRAPH 1990.
- [14] G. M. Nielson. Smooth interpolation of orientations. In N.M. Thalman and D. Thalman, editors, *Computer Animation '93*, pages 75–93, Tokyo, June 1993. Springer-Verlag.
- [15] G.M. Nielson and Dan R. Olson. Direct manipulation techniques for 3d objects using 2d locator devices. In *Computer Graphics*, pages 175–182, 1987. Proceedings of 1986 Workshop on Interactive 3D Graphics.
- [16] Cary B. Phillips, Norman I. Badler, and John Granieri. Automatic viewing control for 3d direct manipulation. In *Computer Graphics*, pages 71–74, 1992. Proceedings of 1992 Symposium on Interactive 3D Graphics.
- [17] Warren Robinett and Richard Holloway. Implementation of flying, scaling, and grabbing in virtual worlds. In *Computer Graphics*, pages 189–192, 1992. Proceedings of 1992 Symposium on Interactive 3D Graphics.
- [18] John Schlag. Using geometric constructions to interpolate orientation with quaternions. In James Arvo, editor, *Graphics Gems II*, pages 377–380. Academic Press, 1991.
- [19] K. Shoemake. Animating rotation with quaternion curves. In *Computer Graphics*, volume 19, pages 245–254, 1985. Proceedings of SIGGRAPH 1985.
- [20] K. Shoemake. Animation with quaternions. Siggraph Course Lecture Notes, 1987.
- [21] Ken Shoemake. Arcball rotation control. In Paul Heckbert, editor, *Graphics Gems IV*, pages 175–192. Academic Press, 1994.
- [22] Ken Shoemake. Fiber bundle twist reduction. In Paul Heckbert, editor, *Graphics Gems IV*, pages 230–236. Academic Press, 1994.
- [23] N. Steenrod. *The Topology of Fibre Bundles*. Princeton University Press, 1951. Princeton Mathematical Series 14.
- [24] P. W. Thorndyke and S. E. Goldin. Spatial learning and reasoning skill. In H.L. Pick and L.P. Acredolo, editors, *Spatial Orientation: Theory, Research, and Application*, pages 195–217. Plenum Press, New York, 1983.
- [25] P. W. Thorndyke and B. Hayes-Roth. Differences in spatial knowledge acquired from maps and navigation. *Cognitive Psychology*, 14:560–589, 1982.
- [26] P. W. Thorndyke and C. Stasz. Individual differences in procedures for knowledge acquisition from maps. *Cognitive Psychology*, 12:137–175, 1980.
- [27] C. Ware and S. Osborne. Exploration and virtual camera control in virtual three-dimensional environments. In *Computer Graphics*, volume 24, pages 175–184, 1990. Proceedings of 1990 Symposium on Interactive 3D Graphics.

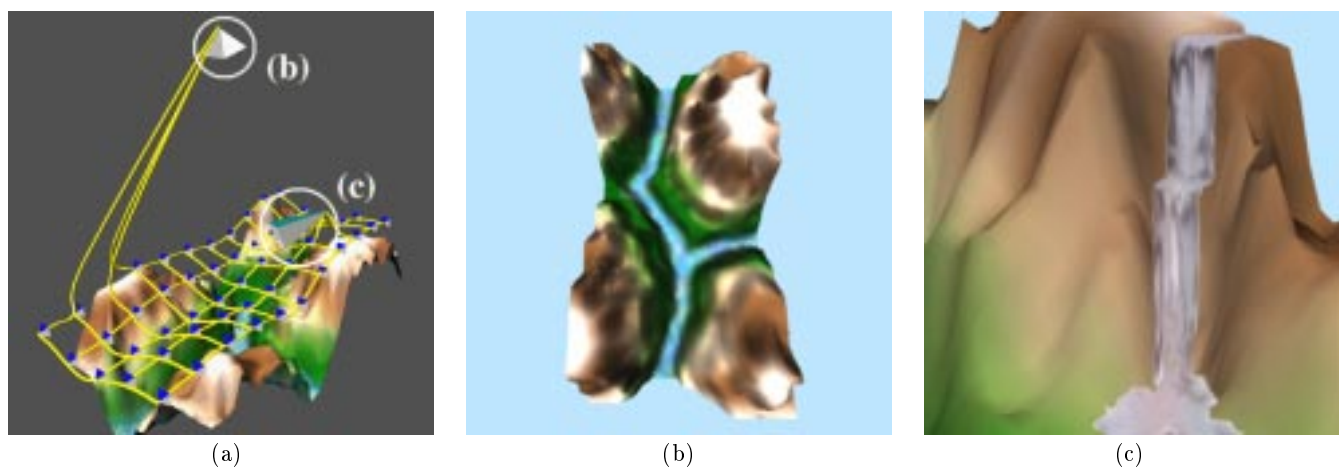

Figure 9: Designer-supplied “vista points” with an “overlook” viewing point at near left and vista point at far right having a telephoto lens pointing back towards base of overlook. (a) View of constraint surface and camera model control points with vista points. (b) View of scene from overlook. (c) Zoomed view of base of overlook from vista point.

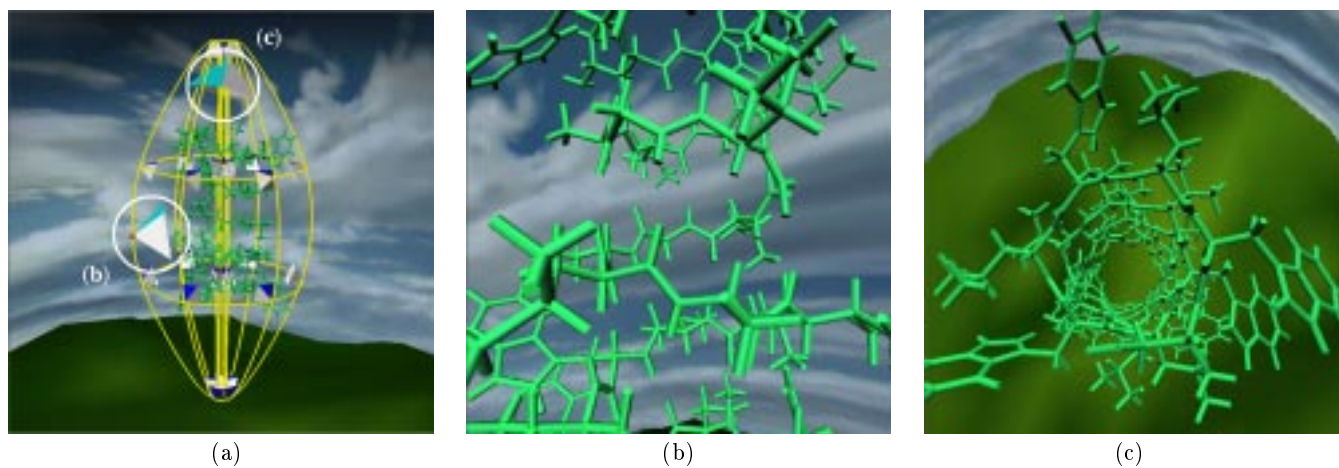

Figure 10: (a) Toroidal constraint surface appropriate to the large cylindrical molecule shown. (b) Choice of camera parameters at the midsection of the molecule. (c) Choice of camera parameters at the ends of the molecule provides a clear holistic view down the central core.

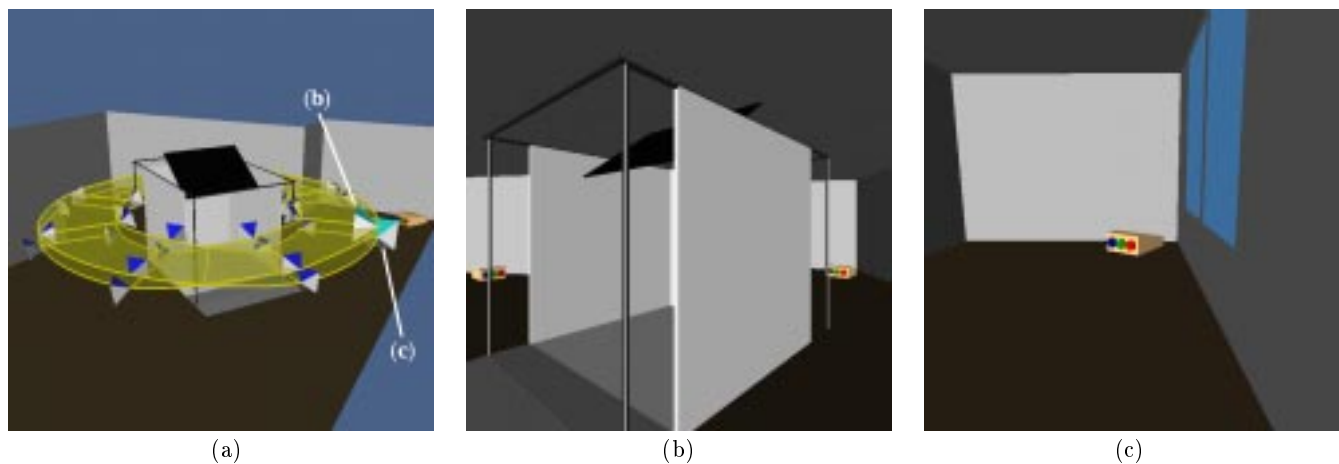

Figure 11: Multiple valued navigation surface; each layer can have independently chosen camera models. (a) View of constraint surface. (b) View from marked point first time around the path. (c) View from marked point second time around the path, showing a different detail to the viewer.